

▼ SG11TM



- For use on all flange types with bolt-hole sizes ranging from 17,5 mm to 62,0 mm
- Unique expanding collet technology
- Little or no access gap required
- Secure bolt-hole locking mechanism.

OPERATING BENEFITS

- Time-saving, simple operation
- Measurable, controlled flange spreading force
- Virtually universal, the Secure-Grip Flange Spreader range covers ANSI, DIN, SPO, ASME, API and BS flanges.

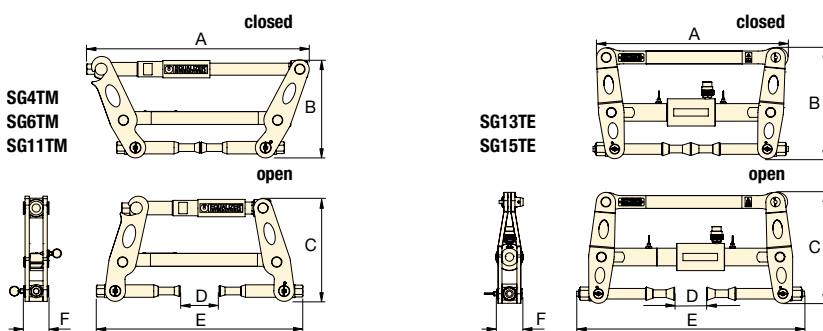

Range of Application

For a detailed range of application please request the Secure-Grip Mechanical or Hydraulic Operator Instruction Sheet.



CAUTION

A minimum of two Flange Spreading Tools must be used when opening flange joints. This will enable the operator to maintain an equal spreading distance across the flange faces.

Flange Dimensions

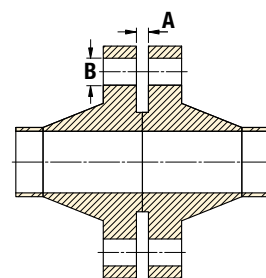

Model Number Tool Kit	Type*	Maximum Spreading Force Per Tool (kN)	Spreading Distance Maximum (mm)	Flange Dimensions (mm)		Tool Dimensions (mm)						Tool Weight (kg)	Kit Weight (kg)	Case Dimensions (mm)	Tool Number
				Minimum Access Gap A	Bolt-hole Diameter B	A	B	C	D	E	F				
SG4TMSTD	M	37,0	75	0	17,5 - 23	398	190	182	75	385	48	4,5	12,8	520x375x165	SG4TM
SG6TMSTD	M	60,0	80	0	24 - 30	468	245	252	80	444	52	7,5	16,0	640x540x165	SG6TM
SG11TMSTD	M	110,0	90	0	30 - 39	516	250	263	90	462	60	10,5	20,0	640x540x165	SG11TM
SG13TESTD	H	130,0	115	0	38 - 49	516	303	314	115	630	72	21,5	40,5	890x570x165	SG13TE
SG15TESTD	H	150,0	100	0	47,5 - 62	600	346	380	100	720	80	26,0	45,0	890x570x165	SG15TE

* M = Mechanical
H = Hydraulic

Flange Spreading Tools

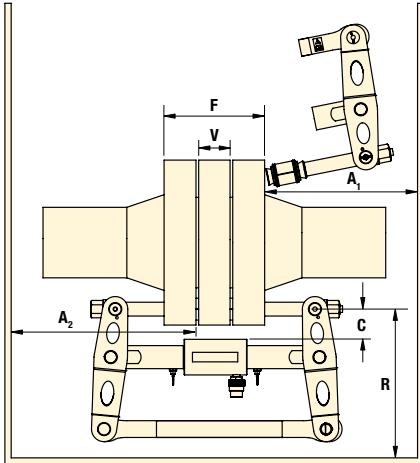

Spreading Force:
37,0 - 150,0 kN

Spreading Distance:
0 - 115 mm

Maximum Operating Pressure:
700 bar *

* Only relevant for hydraulic tools

SG Series



Model Number	Flange Joint Thickness F			Valve / Spacer Thickness V			Flange Clearance C		Radial Space R		Axial Space (for installation) A ₁		Axial Space (installed) A ₂		Tool Number
	Min. (mm)	Max. (mm)	Measured: From / To	Min. (mm)	Max. (mm)	Measured: From / To	Max. (mm)	Measured: From / To	Min. (mm)	Measured: From / To	Min. (mm)	Measured: From / To	Min. (mm)	Measured: From / To	
SG4TMSTD	60	185	Outside face of flange /	0*	45*	Inside face of flange /	50	Bolt-hole circle / Largest OD of valve/spacer	170	Bolt-hole circle / Closest obstruction	170	Outside face of flange / Closest obstruction	200	Inner face of flange / Closest obstruction	SG4TM
SG6TMSTD	60	210		0*	50*		55		230		200		234		
SG11TMSTD	96	240	Outside face of flange /	0*	60*	Inside face of flange /	60	Bolt-hole circle / Largest OD of valve/spacer	240	Bolt-hole circle / Closest obstruction	223	Outside face of flange / Closest obstruction	258	Inner face of flange / Closest obstruction	SG11TM
SG13TESTD	120	310		0*	95*		70		280		310		260		
SG15TESTD	140	400	0*	80*	80	370	380	315	SG15TE						

* Short Collet Holder Kits (SCH) are available which can offer improved range of application.

SG4TM MECHANICAL TOOL KIT



- 1 x SG4TM Tool
- 1 x 150 mm Vernier Calliper
- 1 x 3/8" Drive Torque Wrench and 16 mm Socket
- 1 x Safety Block
- 2 x M16 (5/8") Collets
- 2 x M20 (3/4") Collets
- 1 x Aluminium Carry Case with Protective Foam Inserts

SG6TM MECHANICAL TOOL KIT



- 1 x SG6TM Tool
- 1 x 150 mm Vernier Calliper
- 1 x 3/8" Drive Torque Wrench and 21 mm Socket
- 1 x Safety Block
- 2 x M24 (7/8") Collets
- 2 x M27 (1") Collets
- 1 x Aluminium Carry Case with Protective Foam Inserts

SG11TM MECHANICAL TOOL KIT



- 1 x SG11TM Tool
- 1 x 150 mm Vernier calliper
- 1 x 1/2" Drive torque wrench and 24 mm socket
- 1 x Safety block
- 2 x M30 (1-1/8") Collets
- 2 x M33 (1-1/4") Collets
- 2 x M36 (1-3/8") Collets
- 1 x Aluminium Carry Case with Protective Foam Inserts

SG13TE HYDRAULIC TOOL KIT



- 1 x SG13TE Tool
- 1 x 700 bar HP550S Single Port Sealed Hand Pump with Gauge
- 1 x 700 bar Hydraulic Hose, 2 m
- 1 x 150 mm Vernier Calliper
- 1 x 1/2" Square Drive Flexible Handle
- 1 x 30 mm Socket
- 1 x Safety Block
- 2 x M39 (1-1/2") Collets
- 2 x M42 (1-5/8") Collets
- 2 x M45 (1-3/4") Collets
- 1 x Aluminium Carry Case with Protective Foam Inserts

SG15TE HYDRAULIC TOOL KIT



- 1 x SG15TE Tool
- 1 x 700 bar HP550S Single Port Sealed Hand Pump with Gauge
- 1 x 700 bar Hydraulic Hose, 2 m
- 1 x 300 mm Vernier Calliper
- 1 x 1/2" Square Drive Flexible Handle
- 1 x 36 mm Socket
- 1 x Safety Block
- 2 x M48 (1-7/8") Collets
- 2 x M52 (2") Collets
- 2 x M56 (2-1/4") Collets
- 1 x Aluminium Carry Case with Protective Foam Inserts

▼ SG18TE & SG25TE



- Applicable for larger-sized flanges
- Actuated by an external hand pump
- Suitable for bolt holes from 59,5 to 108 mm.



Range of Application

For a detailed range of application please request the Secure-Grip In-Line Hydraulic Operator Instruction Sheet.



CAUTION

A minimum of two Flange Spreading Tools must be used when opening flange joints. This will enable the operator to maintain an equal spreading distance across the flange faces.

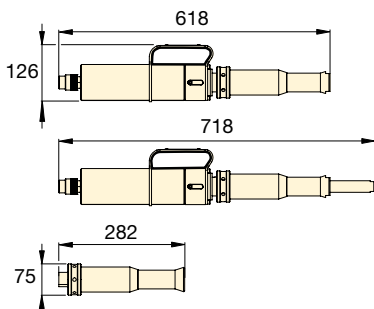

SG18TE

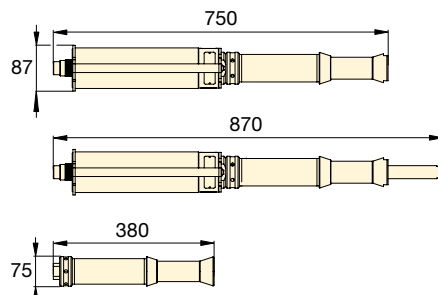

SG25TE

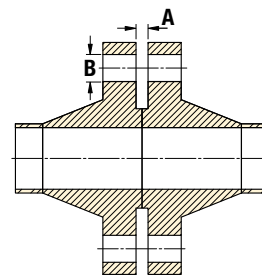

Flange Dimensions

Model Number Tool Kit	Type	Maximum Spreading Force Per Tool (kN)	Spreading Distance Maximum (mm)	Flange Dimensions (mm)		Tool Weight (kg)	Kit Weight (kg)	Case Dimensions (mm)	Tool Number
				Minimum Access Gap A	Bolt-hole Diameter B				
SG18TESTD	Hydraulic	180,0	100	0	59,5 - 75	14	45	890 x 570 x 165	SG18TE
SG25TESTD	Hydraulic	250,0	120	0	75 - 108	24	50	890 x 570 x 165	SG25TE

Flange Spreading Tools

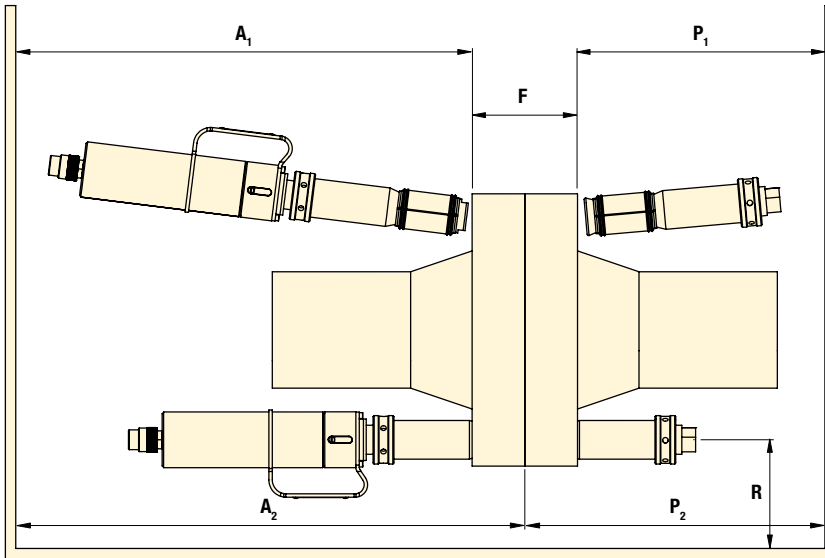

SG Series



Spreading Force:

180,0 - 250,0 kN

Spreading Distance:

0 - 120 mm

Maximum Operating Pressure:

700 bar

Model Number Tool Kit	Flange Joint Thickness F			Radial Space R		Axial Space (for installation) A1		Axial Space (installed) A2		Axial Plug Space (for installation) P1		Axial Plug Space (installed) P2		Tool Number
	Min. (mm)	Max. (mm)	Measured: From / To	Min. (mm)	Measured: From / To	Min. (mm)	Measured: From / To	Min. (mm)	Measured: From / To	Min. (mm)	Measured: From / To	Min. (mm)	Measured: From / To	
SG18TESTD	190	450	Outside face of flange / Outside face of flange	55	Bolt-hole circle / Closest obstruction	620	Outside face of flange / Closest obstruction	900	Inner face of flange / Closest obstruction	283	Outside face of flange / Closest obstruction	283	Inner face of flange / Closest obstruction	SG18TE
SG25TESTD	210	570	Outside face of flange / Outside face of flange	55	Bolt-hole circle / Closest obstruction	750	Outside face of flange / Closest obstruction	1100	Inner face of flange / Closest obstruction	380	Outside face of flange / Closest obstruction	380	Inner face of flange / Closest obstruction	SG25TE

SG18TE HYDRAULIC TOOL KIT



- 1x SG18TE Tool
- 1x Spreading Plug
- 1x 700 bar HP550S Single Port Sealed Hand Pump with Gauge
- 1x 700 bar Hydraulic Hose, 2 m
- 1x 300 mm Vernier Calliper
- 1x 12,5 mm Spacer Plate
- 1x 5 mm Allen Key
- 1x 50 mm Spacer
- 1x Safety Block
- 2x M60 (2-3/8") Collets
- 2x M64 (2-1/2") Collets
- 2x M70 (2-3/4") Collets
- 1x Aluminium Carry Case with Protective Foam Inserts

SG25TE HYDRAULIC TOOL KIT



- 1x SG25TE Tool
- 1x Spreading Plug
- 1x 700 bar HP550S Single Port Sealed Hand Pump with Gauge
- 1x 700 bar Hydraulic Hose, 2 m
- 1x 300 mm Vernier Calliper
- 1x 12,5 mm Spacer Plate
- 1x Safety Block
- 1x Aluminium Carry Case with Protective Foam Inserts

SG25TE COLLETS (AVAILABLE SEPARATELY)

Model Number	Description
673601-01	2x M76 (3") Collets
674801-01	2x M90 (3-1/2") Collets
673901-01	2x M80 (3-1/4") Collets
675101-01	2x M95 (3-3/4") Collets
674501-01	2x M84 (3-3/8") Collets
675601-01	2x M100 (4") Collets